





ENGINEERING

IEC QUICK REFERENCE CHART

- Dimensions are for reference only
- Drawings represent standard TEFC general purpose motors

Contact your local DODGE/Reliance Sales Office at 1-864-284-5700 for "C" dimensions.

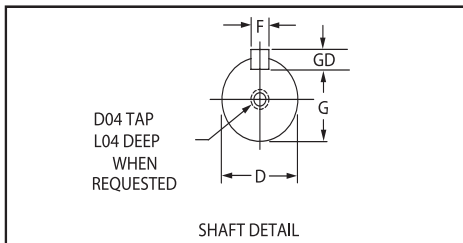
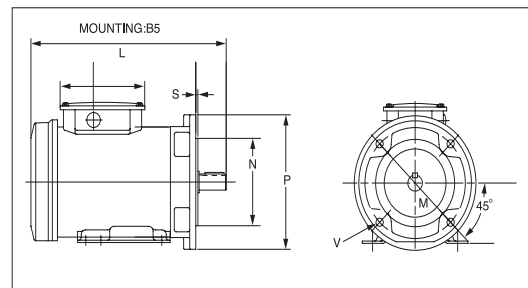
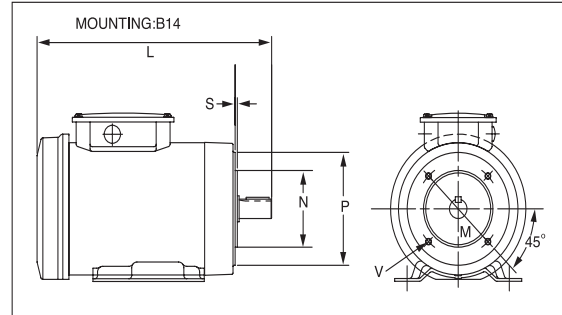
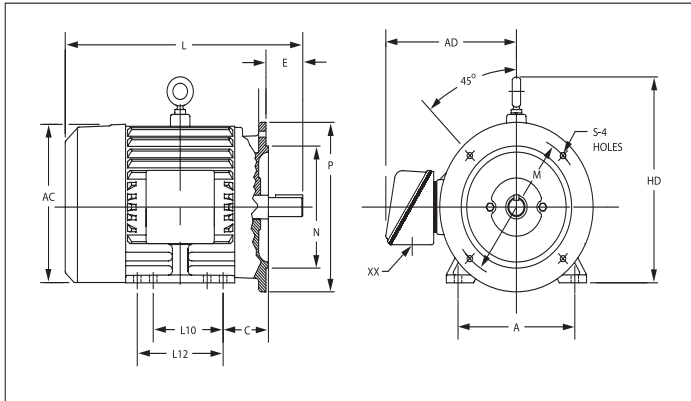

KEY AND KEYSEAT DIMENSIONS									
FRAME	D	G	F	GD	FRAME	D	G	F	GD
71	14	11	5	5	160	37	42	12	8
80	19	15.5	6	6	180	48	42.5	14	9
90	24	20	8	7	200	55	49	16	10
100	28	24	8	7	225	60	53	18	11
112	28	24	8	7	250	70	67.5	20	12
132	38	33	10	8	280	80	71	22	14

Frame	B3 RIGID BASE				SHAFT			B5 FLANGE					B14 FACE					GENERAL		
	A	L10	L12	HD	C	E	D	N	M	P	S	V	N	M	P	S	V	AC	AD	XX
71	-	-	-	-	-	-	-	110	130	160	"3,5"	"9,5"	70	85	105	2,5	M6	143	-	13
80	125	100	-	188	50	40	19	130	165	200	"3,5"	"11,5"	80	100	120	3	M6	143	-	13
90	140	100	125	208	56	50	24	130	165	200	"3,5"	"11,5"	95	115	140	3	M8	163	-	13
100	160	112	140	229	63	60	28	180	215	250	4	14	110	130	160	3,5	M8	175	-	19
112S	190	114	-	301.8	71.4	60	28	180	215	250	4	14	110	130	160	3,5	M8	243	210	32
112M	190	-	140	301.8	71.4	60	28	180	215	250	4	14	110	130	160	3,5	M8	243	210	32
132S	216	140	-	336.6	88.9	80	38	230	265	300	4	14	130	165	200	3,5	M8	286	243	32
132M	216	-	178	336.6	88.9	80	38	230	265	300	4	14	130	165	200	3,5	M8	286	243	32
160M	254	210	-	399	108	110	42	250	300	350	5	18	180	215	250	4	M12	324	320	40
160L	254	-	254	399	108	110	42	250	300	350	5	18	180	215	250	4	M12	324	320	40
180M	279	241	-	436	121	110	48	250	300	350	5	18	398	355	40			398	355	40
180L	279	-	279	436	121	110	48	250	300	350	5	18	398	355	40			398	355	40
200M	318	267	-	486	133	110	55	300	350	400	5	18	442	445	50			442	445	50
200L	318	-	305	486	133	110	55	300	350	400	5	18	442	445	50			442	445	50
225S	356	286	-	545	149	140	60	350	400	450	5	18	490	470	50			490	470	50
225M	356	-	311	545	149	140	60	350	400	450	5	18	490	470	50			490	470	50
250S	406	311	-	616	168	140	65											600	510	63
250M	406	-	349	616	168	140	65											600	535	63
280S	457	368	-	677	190	140	75											650	535	63
280M	457	-	419	677	190	140	75											650	535	63
280K	457	500	-	677	190	140	75											650	535	63
280H	457	630	-	677	190	140	75											650	535	63
L280H	457	635	-	677	202	205	75											650	535	63

**LEGEND**  
Metric Dimensions in MM  
1 mm = .03937"



## NOTES

---

Eccentric Collar Ball Bearings

Setcrew VSC Ball Bearing

Eccentric SXV Collar Ball Bearing

Take-Up Frames

Engineering

Part Number Index

Keyword Index